

# INTERNATIONAL STANDARD

# ISO 9044

Third edition  
2016-07-01

---

---

## Industrial woven wire cloth — Technical requirements and tests

*Tissus métalliques industriels — Exigences techniques et vérifications*



Reference number  
ISO 9044:2016(E)

© ISO 2016



**COPYRIGHT PROTECTED DOCUMENT**

© ISO 2016, Published in Switzerland

All rights reserved. Unless otherwise specified, no part of this publication may be reproduced or utilized otherwise in any form or by any means, electronic or mechanical, including photocopying, or posting on the internet or an intranet, without prior written permission. Permission can be requested from either ISO at the address below or ISO's member body in the country of the requester.

ISO copyright office  
Ch. de Blandonnet 8 • CP 401  
CH-1214 Vernier, Geneva, Switzerland  
Tel. +41 22 749 01 11  
Fax +41 22 749 09 47  
copyright@iso.org  
www.iso.org

# Contents

Page

<b>Foreword</b> .....	<b>iv</b>
<b>1 Scope</b> .....	<b>1</b>
<b>2 Normative references</b> .....	<b>1</b>
<b>3 Terms and definitions</b> .....	<b>1</b>
<b>4 Requirements</b> .....	<b>4</b>
4.1 Aperture width and wire diameter combination.....	4
4.2 Maximum permissible errors on aperture width.....	4
4.3 Permissible number of major blemishes.....	7
4.4 Maximum permissible error on overall size.....	7
4.5 Flatness.....	8
4.6 Surface conditions.....	8
4.7 Weaving wire.....	8
4.7.1 Material.....	8
4.7.2 Maximum permissible error on wire diameter.....	8
<b>5 Test methods</b> .....	<b>8</b>
5.1 Wire diameter, $d$ (see <a href="#">4.7.2</a> ).....	8
5.2 Aperture width, $w$ .....	9
5.2.1 Average aperture width maximum permissible error, $Y_i$ (see <a href="#">4.2.1</a> ).....	9
5.2.2 Maximum permissible error of aperture width, $X_i$ (see <a href="#">4.2.3</a> ).....	10
5.3 Material composition.....	10
5.4 Overall size (see <a href="#">4.4</a> ).....	10
5.5 Weaving blemishes.....	11
<b>6 Inspection documents</b> .....	<b>11</b>
6.1 Certificate of compliance with the order.....	11
6.2 Test report.....	11
6.3 Inspection certificate.....	11
6.4 Chemical analysis.....	11
6.5 Other tests.....	11
<b>7 Ordering information</b> .....	<b>11</b>
7.1 Essential information.....	11
7.2 Additional information.....	11
<b>8 Delivery</b> .....	<b>12</b>
8.1 Rolls.....	12
8.2 Packing.....	12
8.3 Labelling.....	12
<b>Annex A (informative) Major blemishes</b> .....	<b>13</b>
<b>Annex B (informative) Calculation of mean value and standard deviation</b> .....	<b>14</b>
<b>Annex C (informative) Calculation of sub values for standard deviation <math>s_0</math> in <a href="#">Table 1</a></b> .....	<b>16</b>
<b>Bibliography</b> .....	<b>17</b>

## Foreword

ISO (the International Organization for Standardization) is a worldwide federation of national standards bodies (ISO member bodies). The work of preparing International Standards is normally carried out through ISO technical committees. Each member body interested in a subject for which a technical committee has been established has the right to be represented on that committee. International organizations, governmental and non-governmental, in liaison with ISO, also take part in the work. ISO collaborates closely with the International Electrotechnical Commission (IEC) on all matters of electrotechnical standardization.

The procedures used to develop this document and those intended for its further maintenance are described in the ISO/IEC Directives, Part 1. In particular the different approval criteria needed for the different types of ISO documents should be noted. This document was drafted in accordance with the editorial rules of the ISO/IEC Directives, Part 2 (see [www.iso.org/directives](http://www.iso.org/directives)).

Attention is drawn to the possibility that some of the elements of this document may be the subject of patent rights. ISO shall not be held responsible for identifying any or all such patent rights. Details of any patent rights identified during the development of the document will be in the Introduction and/or on the ISO list of patent declarations received (see [www.iso.org/patents](http://www.iso.org/patents)).

Any trade name used in this document is information given for the convenience of users and does not constitute an endorsement.

For an explanation on the meaning of ISO specific terms and expressions related to conformity assessment, as well as information about ISO's adherence to the WTO principles in the Technical Barriers to Trade (TBT) see the following URL: [Foreword - Supplementary information](#)

ISO 9044 was prepared by Technical Committee ISO/TC 24, *Particle characterization including sieving*, Subcommittee SC 8, *Test sieves, sieving and industrial screens*.

This third edition cancels and replaces the second edition (ISO 9044:1999), which has been technically revised.

# Industrial woven wire cloth — Technical requirements and tests

## 1 Scope

This International Standard defines terms regarding industrial woven wire cloth for screening purposes and specifies maximum permissible error, requirements, and test methods.

It applies to industrial woven wire cloth with square apertures, made of steel, stainless steel, or non-ferrous metals (see ISO 4783-2). It does not apply to woven wire cloth coated after weaving nor does it apply to pre-crimped and welded wire screens which are covered in ISO 4783-3 and ISO 14315.

It is of limited application to woven wire cloth used for purposes other than screening which may necessitate other requirements. The alternative requirements may be agreed between the purchaser and the supplier at the time of placing the order.

## 2 Normative references

The following documents, in whole or in part, are normatively referenced in this document and are indispensable for its application. For dated references, only the edition cited applies. For undated references, the latest edition of the referenced document (including any amendments) applies.

ISO 2194, *Industrial screens — Woven wire cloth, perforated plate and electroformed sheet — Designation and nominal sizes of openings*

ISO 4782, *Metal wire for industrial wire screens and woven wire cloth*

ISO 4783-1, *Industrial wire screens and woven wire cloth — Guide to the choice of aperture size and wire diameter combinations — Part 1: Generalities*

ISO 4783-2:1989, *Industrial wire screens and woven wire cloth — Guide to the choice of aperture size and wire diameter combinations — Part 2: Preferred combinations for woven wire cloth*

## 3 Terms and definitions

For the purposes of this document, the following terms and definitions apply.

### 3.1 aperture width

*w*

distance between two adjacent warp or weft wires, measured in the projected plane at the mid-positions

Note 1 to entry: See [Figure 1](#).

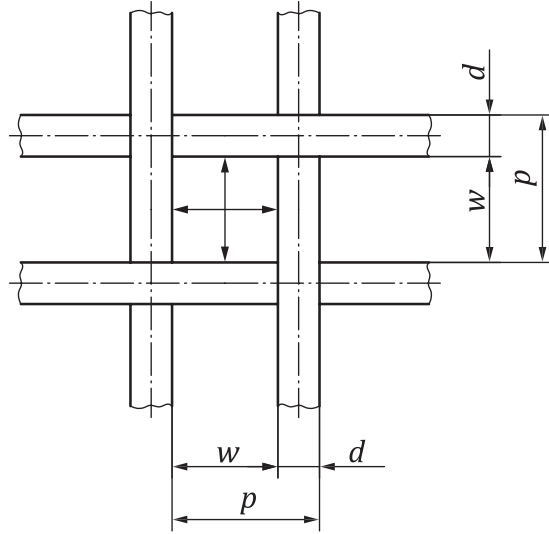

**Figure 1 — Aperture width, wire diameter, and pitch**

**3.2 wire diameter**

*d*  
diameter of the wire in the wire screen

Note 1 to entry: The wire diameter may be altered slightly during the weaving process. See [Figure 1](#).

**3.3 pitch**

*p*  
distance between the mid-points of two adjacent wires

Note 1 to entry: The pitch is the sum of the aperture width, *w*, and the wire diameter, *d*. See [Figure 1](#).

**3.4 warp**

all wires running lengthwise in the cloth as woven

**3.5 weft**

all wires running crosswise in the cloth as woven

**3.6 number of apertures per unit length**

*n*  
number of measurements taken

**3.7 open screening area**

*A<sub>0</sub>*  
percentage of the surface of all the apertures in the total screening surface

Note 1 to entry: The open screening area is calculated as the ratio of the square of the nominal aperture width, *w*, and the square of the nominal pitch, *p* = *w* + *d*, rounded to a full percentage value:

$$A_0 = \frac{w^2}{(w + d)^2} \cdot 100\%$$

### 3.8

#### type of weave

way in which the *warp* (3.4) and *weft* (3.5) wires cross each other

Note 1 to entry: Industrial woven wire cloth is manufactured with square apertures in plain or twilled weave (see Figure 2).

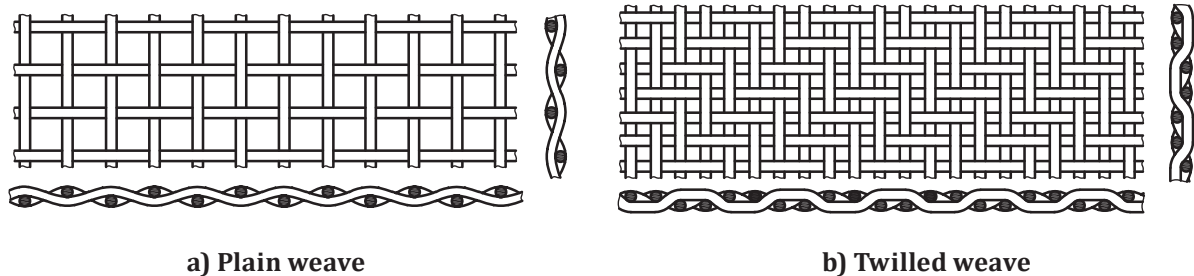

Figure 2 — Types of weave

### 3.9

#### firmness of woven wire cloth

tension existing between the crossing *warp* (3.4) and *weft* (3.5) wires and which determines the firmness of the wire cloth

Note 1 to entry: It is affected by the relationship of  $w$  to  $d$  and by the type of weave.

### 3.10

#### mass per unit area

$\rho_A$

quantity calculated using the following formula:

$$\rho_A = \frac{d^2 \cdot \rho}{618,1 \cdot (w + d)}$$

where

$d$  is the wire diameter, in mm;

$w$  is the aperture width, in mm;

$\rho$  is the material density, in kg/m(s)<sup>3</sup>;

$\rho_A$  is the mass per unit area, in kg/m(s)<sup>2</sup>

Note 1 to entry: This formula gives the calculated mass per unit area.

Note 2 to entry: The value 618,1 is based on the crimped wire.

Note 3 to entry: Typical values of  $\rho$  for various materials are given in ISO 4783-2:1989, Table 2. For example, the mass per unit area for plain or carbon steel with a density of 7 850 kg/m<sup>3</sup> can be calculated using the formula provided as follows:

$$\rho_A = \frac{d^2 \cdot 7\,850}{618,1 \cdot (w + d)} = \frac{12,7 \cdot d^2}{w + d}$$

The formula provided can also be used to calculate the *wire diameter* (3.2),  $d$ , when the *pitch* (3.3),  $p$ , or  $(w + d)$ , and the mass per unit area,  $\rho_A$ , are known. In the case of plain or carbon steel ( $\rho = 7\,850\text{ kg/m}^3$ ), see the following formula:

$$d = \sqrt{\frac{\rho_A \cdot p}{12,7}}$$

### 3.11 major blemishes

production defects which significantly affect the *aperture width* (3.1) or surface quality of the wire cloth

Note 1 to entry: See [Annex A](#) for information.

## 4 Requirements

### 4.1 Aperture width and wire diameter combination

Unless otherwise agreed between the supplier and the purchaser, the aperture width and wire diameter combination shall be selected from ISO 2194, ISO 4782, ISO 4783-1, or ISO 4783-2, as appropriate.

### 4.2 Maximum permissible errors on aperture width

The maximum permissible errors on aperture width are given in [Table 1](#).

In [Table 1](#) and [Formulae \(1\)](#) to [\(7\)](#), the suffix “i”, used with the symbols denotes “industrial wire cloth”. In [Formulae \(1\)](#) to [\(8\)](#),  $X_i$ ,  $Y_i$ ,  $s_0$ , and  $w$  are expressed in micrometres.

NOTE Nominal apertures in [Table 1](#) lower than 1 mm are in  $\mu\text{m}$ , higher or equal in mm.



Table 1 — Maximum permissible error of aperture width

	Nominal aperture width	Maximum permissible error on aperture width, $w$ for woven wire cloth made of...					
		austenite stainless steel			steel, copper, brass, bronze, aluminium, non-ferrous steels, and other stainless steels without austenite stainless steel		
	(1)	(2)	(3)	(4)	(5)	(6)	(7)
mm	$w$	$\pm Y_i$	$s_0$	$+X_i$	$\pm Y_i$	$s_0$	$+X_i$
	16	0,69	0,913	1,89	0,78	1,026	2,09
	12,5	0,54	0,741	1,58	0,62	0,831	1,74
	10	0,43	0,616	1,34	0,50	0,690	1,48
	8	0,35	0,513	1,14	0,40	0,574	1,26
	6,3	0,28	0,423	0,96	0,32	0,473	1,06
	5	0,22	0,352	0,82	0,25	0,393	0,90
	4	0,18	0,295	0,70	0,20	0,330	0,77
	3,15	0,14	0,245	0,59	0,16	0,274	0,65
	2,5	0,11	0,205	0,50	0,13	0,229	0,55
	2	0,09	0,174	0,43	0,10	0,193	0,47
	1,6	0,07	0,147	0,37	0,08	0,164	0,41
	1,25	0,06	0,122	0,31	0,07	0,136	0,34
	1	0,05	0,104	0,27	0,05	0,116	0,30
$\mu\text{m}$	$w$	$\pm Y_i$	$s_0$	$+X_i$	$\pm Y_i$	$s_0$	$+X_i$
	800	39	88,8	231	44	98,8	255
	630	31	75,1	197	35	83,5	218
	500	25	64,1	170	29	71,2	188
	400	21	55,1	147	24	61,2	163
	315	17	47,0	127	19	52,2	140
	250	13,8	40,5	110	15,8	45,0	121
	200	11,6	35,2	96	13,2	39,0	106
	160	9,7	30,6	84	11,1	34,0	93
	125	8,1	26,4	73	9,3	29,3	80
	100	7,0	23,2	64	8,0	25,7	71
	80	6,0	20,5	57	6,9	22,7	63
	63	5,2	17,9	50	6,0	19,9	55
	50	4,6	15,9	44	5,3	17,6	49
	40	4,2	14,2	39	4,8	15,7	43
	32	3,8	12,7	35	4,3	14,1	39
25	3,5	9,3	25	3,9	9,5	25	
20	3,2	7,6	20	3,7	7,8	20	

**4.2.1**  $Y_i$  is the maximum permissible error of the arithmetical mean value of the aperture widths measured and calculated separately in both warp and weft directions.

The arithmetical average aperture width shall not deviate from the nominal size by more than  $\pm Y$ ; where

$$Y_i = \left[ \frac{w^{0,98}}{27} + 1,6 \right] \cdot 1,4 \quad (1)$$

for column 2 in [Table 1](#) and

$$Y_i = \left[ \frac{w^{0,98}}{27} + 1,6 \right] \cdot 1,6 \quad (2)$$

for column 5 in [Table 1](#).

**4.2.2** The maximum standard deviation  $s$  of the aperture widths measured and calculated separately in both warp and weft directions shall not exceed the values of  $s_0$  in [Table 1](#), columns 3 and 6.

$$s = \sqrt{\frac{1}{n-1} \sum_{i=1}^n (w_i - \bar{w})^2} \quad (3)$$

with

$$\bar{w} = \frac{1}{n} \sum_{i=1}^n w_i \quad (4)$$

**4.2.3** No aperture width shall exceed the nominal size by more than the value  $+X$ .

It is the maximum permissible deviation of a single aperture measured in one direction (warp or weft) and is calculated using [Formulae \(5\)](#) and [\(6\)](#):

$$X_i = \left[ \frac{2w^{0,75}}{3} + 4w^{0,25} \right] \cdot 1,9 \quad (5)$$

for column 4 in [Table 1](#) and

$$X_i = \left[ \frac{2w^{0,75}}{3} + 4w^{0,25} \right] \cdot 2,1 \quad (6)$$

for column 7 in [Table 1](#), but with a maximum value of  $X_i = w$ .

A line of apertures exceeding the value  $X_i$  is deemed to be a major blemish (see [Annex A](#)).

As, on the basis of experience, negative deviations of single aperture widths do not affect the screening process, values for  $X_i$  have only positive deviations.

**4.2.4** Calculation of  $s_0$ .

The maximum standard deviation of the aperture sizes in warp and weft directions taken separately shall not exceed the values of  $s_0$  in [Tables 1](#), column 3 and 6.

The standard deviation  $s_0$  is calculated normal distribution  $\Phi(w)$  based of not more than 6 % of a total number of aperture size between  $+X$  and  $+Z$ .

$$\Phi\left(\frac{X_i}{s_0}\right) - \Phi\left(\frac{Z_i}{s_0}\right) = 0,06; Z = \frac{X + |Y|}{2} \quad (7)$$

**4.2.5** Calculation of sub-values aperture width for  $s_0$  in [Table 1](#), column 3 and 6:

$$s_0 = \frac{w_x - w_u}{w_o - w_u} \cdot (s_o - s_u) + s_u \quad (8)$$

where

$w_x$  is the sub-value aperture width to be calculated;

$w_u$  is the lower table value aperture width;

$w_o$  is the upper table value aperture width;

$s_u$  is the lower table value standard deviation;

$s_o$  is the upper table value standard deviation.

NOTE See [Annex C](#) for example to calculate the sub values.

### 4.3 Permissible number of major blemishes

**4.3.1** Woven wire cloth cannot be produced commercially without there being some manufacturing blemishes.

The supplier and the purchaser shall agree upon the number and nature of major blemishes which are permissible per unit area of the wire screen. The percentage yield of the wire cloth shall be agreed on with the purchaser and will vary according to the aperture width and size of the piece of woven wire cloth.

Unless otherwise agreed between the supplier and purchaser, the maximum number of major weaving blemishes (see [Annex A](#)), in any roll or roll piece of wire cloth shall not exceed the values given in [Table 2](#).

**Table 2 — Permissible number of major blemishes**

Nominal aperture width, $w$ , mm	Maximum number of major blemishes per 10 m <sup>2</sup>
$1 \leq w \leq 16$	3
$0,125 \leq w < 1,0$	4
$0,063 \leq w < 0,125$	5
$w < 0,063$	6

**4.3.2** Minor manufacturing blemishes which do not produce oversize apertures or do not significantly affect the surface quality of the wire screen shall be acceptable, unless otherwise specified.

### 4.4 Maximum permissible error on overall size

When measured as specified in [5.4](#), the overall size of pieces of wire cloth shall conform to the following requirements.

**4.4.1** The maximum permissible error on width, of trimmed wire cloth rolls and roll lengths, shall be 0/+2 % of nominal.

**4.4.2** The maximum permissible error on length and width, of square and rectangular pieces, shall be the larger of  $\pm 0,5$  % or  $\pm 1$  pitch.

**4.4.3** For cut-to-size pieces, the permissible number of major blemishes and their positions shall be agreed with the purchaser.

Otherwise, the permissible number of major blemishes in cut-to-size pieces shall be determined according to [Table 2](#).

#### **4.5 Flatness**

Unless otherwise agreed between the supplier and purchaser, wire cloth rolls and pieces shall not necessarily be supplied to lie flat.

If the purchaser requires flat wire cloth, the means of verifying flatness shall be agreed with the supplier.

#### **4.6 Surface conditions**

Woven wire cloth may be covered with a film of oil as a result of the weaving process.

The wires may show traces of auxiliary materials used in the drawing process. Depending on the wire material, there may be traces of corrosion.

The surface may show markings caused by the drawing and/or weaving process.

NOTE The depth of crimp generally differs between warp and weft wires.

#### **4.7 Weaving wire**

##### **4.7.1 Material**

The purchaser shall specify the choice of material with respect to

- a) the final application of the woven wire cloth, e.g. resistance to environmental corrosion, compatibility with food products, etc., and
- b) further processing, e.g. suitability for shaping, welding, and surface treatment.

Materials shall be designated in accordance with appropriate standards or, if none exist, in accordance with commercial specifications.

##### **4.7.2 Maximum permissible error on wire diameter**

Prior to weaving, the maximum permissible error on wire diameter shall be as specified in ISO 4782. The weaving process normally distorts the wire and affects its diameter, which is no longer maximum permissible error after weaving. The wire diameter is measured as specified in [5.1](#).

### **5 Test methods**

#### **5.1 Wire diameter, $d$ (see [4.7.2](#))**

Prior to weaving, the diameter of the wire shall be calculated as the mean of any two measurements taken at right angles at the same cross-section.

The wire diameter may be determined after weaving by using one of the following procedures:

- a) by measuring wires which have been loosened from the woven wire cloth (see [Figure 3](#));
- b) by measuring the wires in the cloth, if there is sufficient space for the measuring instrument;
- c) by calculation from the mass per unit area using [Formula \(3\)](#);

d) by an optical projection or scanning method.

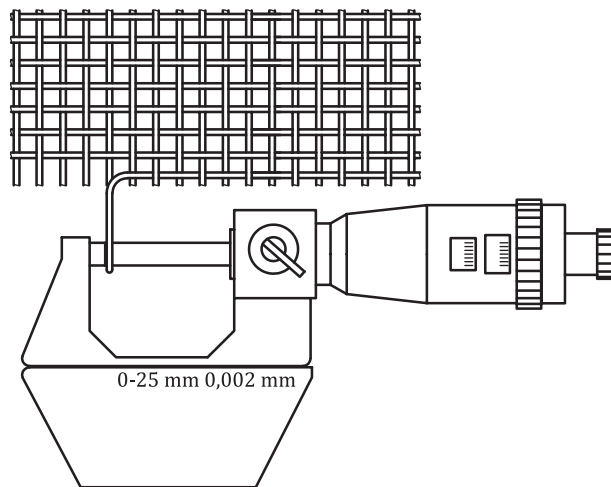

Figure 3 — Example of method for measuring wire diameters

## 5.2 Aperture width, $w$

### 5.2.1 Average aperture width maximum permissible error, $Y_i$ (see 4.2.1)

#### 5.2.1.1 Aperture widths greater than 4,0 mm

A steel rule, graduated in millimetres, shall be laid along the warp and weft direction of the wire cloth. The span of ten pitches shall be measured to the nearest millimetre. The test result shall be divided by ten, to give the average pitch, from which shall be deducted the wire diameter to give average width (see Figure 4). Optical measurement devices are allowed if they provide a resolution of less than 0,1mm.

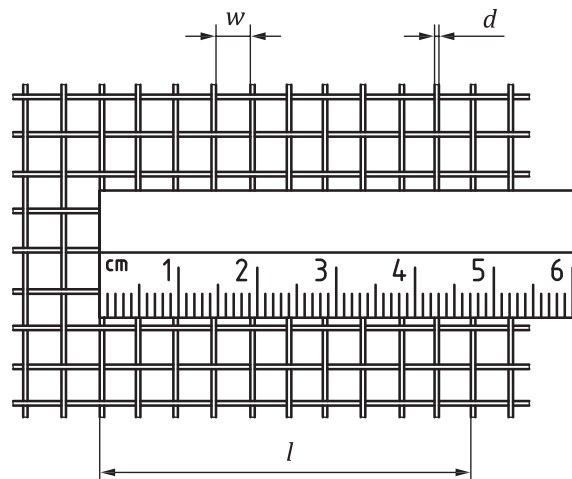

Figure 4 — Measured row with 10 pitches and 47,5 mm length

#### 5.2.1.2 Aperture widths from 1 mm up to 4 mm

The test procedure shall be as in 5.2.1.1 but the span of 20 pitches shall be measured and the test result divided by 20, to give the average pitch.

### 5.2.1.3 Aperture widths less than 1 mm

Each of the following is a possible test procedure.

- a) The number of wires visible under low-powered magnification over a known distance (counting glass) may be counted (see [Figure 5](#)). The average aperture width may be calculated by deducting the wire diameter from the average pitch.
- b) The number of wires per unit length in the warp or weft direction may be counted by using a microscope.
- c) An optical interference method may be used to determine the number of pitches per unit length.
- d) Profile projector, image analyser, or optical scanning instruments may be used. On these instruments, a span of five times ten pitches is recommended for both warp and weft directions.
- e) Minimum number of aperture width to be measured is 20 randomly spaced in warp and weft direction.

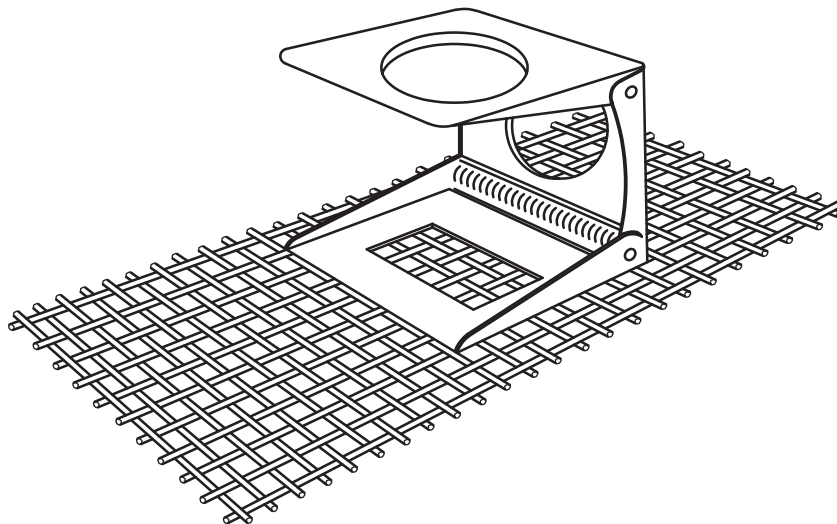

Figure 5 — Counting glass for measuring aperture widths less than 1 mm

### 5.2.2 Maximum permissible error of aperture width, $X_i$ (see [4.2.3](#))

When evaluating the test results, a margin of 10 mm on both sides of the roll and, for an aperture width exceeding 5 mm, a margin equivalent to two apertures on each side shall be disregarded.

A line of apertures exceeding the value  $X_i$  is deemed to be a major blemish (see [Annex A](#)).

## 5.3 Material composition

For chemical analysis of the wire material, the wire drawer's or wire processor's batch or melt number analysis shall be used, if applicable.

When chemical analysis is to be carried out, it shall be performed in accordance with the requirements of the National/International Standard used to designate the material.

### 5.4 Overall size (see [4.4](#))

Overall size shall be measured using suitable metal tapes or rules.

## 5.5 Weaving blemishes

Wire cloth shall be checked visually for blemishes.

## 6 Inspection documents

### 6.1 Certificate of compliance with the order

The statement of compliance shall confirm that the goods comply with the requirements of this International Standard.

### 6.2 Test report

The test report shall confirm that the goods comply with the requirements of this International Standard.

### 6.3 Inspection certificate

At the specified request of the purchaser, a certificate shall be issued stating separately the test results for the average aperture size and wire diameter, in both the warp and weft direction of the wire cloth.

### 6.4 Chemical analysis

When a supplier can demonstrate traceability via certified quality assurance system procedures, the results from the identified analysis carried out earlier in the manufacturing process may be used for the purpose of consignment certification.

### 6.5 Other tests

Dimension or other tests will be carried out in accordance with the supplier's inspection procedures, unless otherwise agreed with the purchaser.

## 7 Ordering information

### 7.1 Essential information

It is essential that the following information is given by the purchaser to the supplier at the time of enquiry or order to assist the supplier in providing the correct material:

- a) the quantity required;
- b) aperture width,  $w$ ;
- c) wire diameter,  $d$ ;
- d) material;
- e) type of weave, if not plain;
- f) the overall size, including maximum permissible error if other than those specified in [4.4](#).

### 7.2 Additional information

When enquiring or ordering, the purchaser should clearly indicate his specified requirements:

- a) type of inspection documents, if demanded (see [Clause 6](#));

- b) other requirements not specified in this International Standard, if demanded.

## 8 Delivery

### 8.1 Rolls

**8.1.1** A standard roll shall be 25 m or 30 m long. The length of rolls may have a maximum permissible error of  $\pm 10\%$ . The delivered length shall be the length invoiced.

**8.1.2** A roll of woven wire cloth may consist of a maximum of three roll pieces; the minimum length of a roll piece shall be 2,5 m.

**8.1.3** For rolls and roll pieces, the width of the cloth shall not be less than the nominal width, but may be up to 2 % in excess. The overall width shall be measured.

### 8.2 Packing

Unless otherwise agreed between the supplier and purchaser, the woven wire cloth will be packed at the discretion of the supplier.

### 8.3 Labelling

Material supplied shall be identified with the following information:

- a) the supplier's name and/or trademark;
- b) the aperture width,  $w$  (nominal);
- c) the wire diameter,  $d$  (nominal);
- d) the material designation;
- e) the type of weave, if not plain;
- f) the overall sizes and quantity.

If the material delivered consists of rolls or roll pieces, the length of the pieces and their quantity should be shown. Woven wire cloth can be supplied with or without selvedge. Normal delivery would be without selvedge.



## Annex A (informative)

### Major blemishes

<b>Smash:</b>	A complex break-up of the weaving pattern.
<b>Burst:</b>	A tear of variable length in the cloth arising from unsustainable tension during weaving. NOTE Bursts normally occur near the edges.
<b>Broken shot (weft):</b>	A wide aperture or a line of wide apertures left when a broken weft wire partly blocks the laying of the next weft wire.
<b>Variation in weft count:</b>	Irregular weft count over a certain length of the woven wire cloth.
<b>Draw-over:</b>	A certain length of cloth containing no weft wires.
<b>Slack shot (weft) or loop:</b>	A weft wire which is longer than the neighbouring weft wires.
<b>Creeper:</b>	A warp wire which is longer than the neighbouring warp wires.
<b>Reed mark (tramline):</b>	Single line of apertures of excessive width in the warp direction.

## Annex B (informative)

### Calculation of mean value and standard deviation

The standard deviation is calculated using [Formulae \(3\)](#) and [\(4\)](#), as illustrated by the following examples.

Nominal aperture width = 630  $\mu\text{m}$  (austenite stainless steel)

**Table B.1 — Rounded values**

$w_i$	$n_i$	$n_i \cdot w_i$	$(w_i - \bar{w})$	$(w_i - \bar{w})^2$	$n_i (w_i - \bar{w})^2$
600	0	0	-27	752	0
605	1	605	-22	503	503
610	5	3 050	-17	303	1 517
615	18	11 070	-12	154	2 777
620	21	13 020	-7	55	1 156
625	35	21 875	-2	6	205
630	34	21 420	3	7	226
635	19	12 065	8	57	1 092
640	16	10 240	13	158	2 532
645	8	5 160	18	309	2 472
650	0	0	23	510	0
655	0	0	28	761	0
660	0	0	33	1 061	0
<b><math>\Sigma</math></b>	<b>157</b>	<b>98 505</b>			<b>12 480</b>

Maximum permissible error for the mean value of aperture width =  $\pm 31 \mu\text{m}$

Maximum permissible standard deviation of aperture width =  $75,1 \mu\text{m}$

in  $\mu\text{m}$  (rounded value)

$$\bar{w} = \frac{1}{n} \sum_{i=1}^n w_i$$

$$\bar{w} = \frac{1}{157} \cdot 98\,505$$

$$\bar{w} = 627,4$$

$$s = \sqrt{\frac{1}{n-1} \sum_{i=1}^n (w_i - \bar{w})^2}$$

$$s = \sqrt{\frac{1}{157-1} \cdot 12\,480}$$

$$s = 8,9$$

www.iso.org

## Annex C (informative)

### Calculation of sub values for standard deviation $s_0$ in [Table 1](#)

Example for nominal aperture width 900  $\mu\text{m}$  (austenite stainless steel) in  $\mu\text{m}$  (rounded value)

$$s_0 = \frac{w_x - w_u}{w_o - w_u} \cdot (s_o - s_u) + s_u$$

$$s_0 = \frac{900 - 800}{1000 - 800} \cdot (104 - 88,8) + 88,8$$

$$\underline{s_0 = 96,4}$$

## Bibliography

- [1] ISO 4783-3, *Industrial wire screens and woven wire cloth — Guide to the choice of aperture size and wire diameter combinations — Part 3: Preferred combinations for pre-crimped or pressure-welded wire screens*
- [2] ISO 14315, *Industrial wire screens — Technical requirements and testing*
- [3] EN 10204, *Metallic products — Types of inspection documents*

